

# M-85-287 NEBS Certified Enclosure

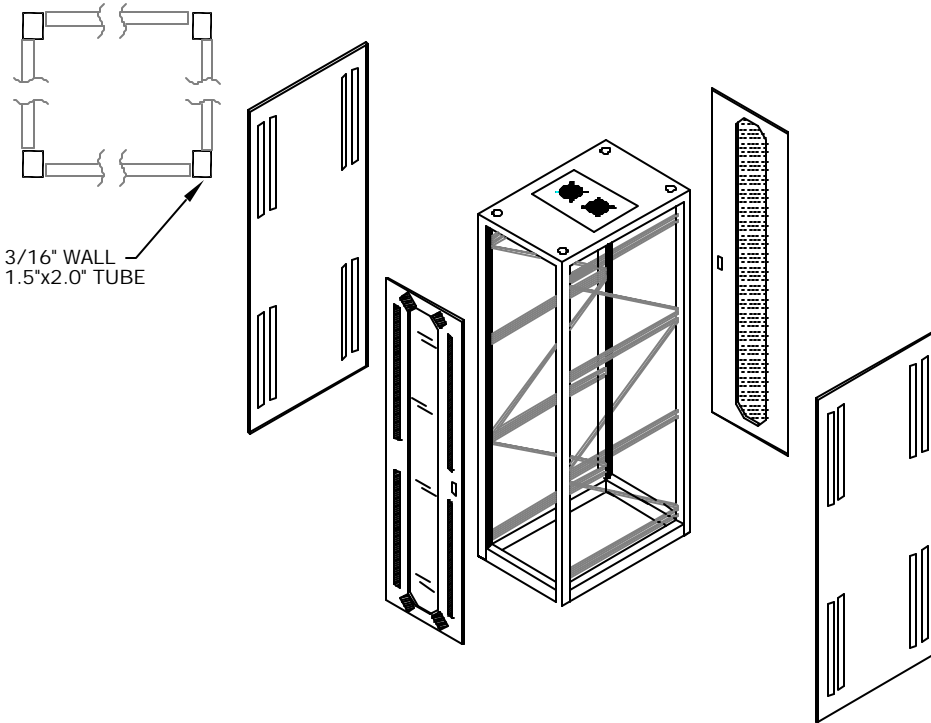

## OUTSIDE DIMENSIONS

**85" High**  
2159 mm  
**28" Wide**  
711 mm  
**36" Deep**  
864 mm

## RAIL TYPES

**M-Frame**  
19" EIA Rackable  
**MU-Frame**  
19" EIA Universal

## RACK UNITS

**45U EIA Rack**  
Spaces  
78.50" Rack Height  
1867 mm

## INSIDE DIMENSIONS

**25.50" Wide**  
648 mm  
24.50" Shelf Width  
622 mm  
**33.50" Deep**  
850 mm  
28.00" Inside Rails  
711 mm  
29.187" Shelf Depth  
741 mm

## CAPACITY

**M-Frame**  
**MS-Frame**  
750 lb.  
340 kg

- LIFETIME WARRANTY
- 14 DAY SATISFACTION GUARANTEE
- Nebs Compliant
- Meets GR-63-COR Specifications
- Reversible left/right doors
- Insert top panel system
- Fully secure, no exposed hardware
- Zero clearance frame coupling

**\*CC = COLOR CODES:** Choose Earth White (EW), IBM White (IW), IBM Blue (IB), Black (BK), Medium Gray (MG)

**FRAMES** Includes: Leveler glides (4), 2 sets rails, hardware kit (24)

Capacity/Type	EIA 19" Rails 10/32 Tapped	EIA 19" Rails Universal	"S" Rails 10/32 Tapped
• Sliding clip 750lb.	M85-287-CC* MH85-287-CC*	MU85-287-CC* MHU85-287-CC*	MS85-287-CC* MSH85-287-CC*

**OPTIONS** All shipped installed when ordered with frame except shelves unless location provided.

• Doors	Mesh	Plexiglass	Plexiglass	Mesh	Vented	Solid
L/R Rev.	Vented Insert	Vented Insert	Insert	Insert		
Front	<b>MDMV185-28-CC*</b>	<b>MDPV185-28-CC*</b>	<b>MDPI85-28-CC*</b>	<b>MDMI85-28-CC*</b>	<b>MDV85-28-CC*</b>	<b>MDS85-28-CC*</b>
Rear	<b>MDMV185-28-CC*</b>	<b>MDPV185-28-CC*</b>	<b>MDPI85-28-CC*</b>	<b>MDMI85-28-CC*</b>	<b>MDV85-28-CC*</b>	<b>MDS85-28-CC*</b>
• Sides	Solid	Solid/Access	Vented			
Left	MSS85-7-CC*	MSSA85-7-CC*	MSV85-7-CC*			
Right	MSS85-7-CC*	MSSA85-7-CC*	MSV85-7-CC*			
• Tops	Dual110cfmFan	Dual240cfmFan	Single550cfmFan	Vented	Mesh	Solid
	MTFI2-110-CC*	MTFI2-240-CC*	MTFI-550-CC*	MTVI-CC*	MTMI-CC*	MTSI-CC*
• Shelves	Roll-Out	Fixed Air-Flow	H.Duty Air-Flow		Keyboard Roll-out	
23.50"D	SER-45-CC*	SEA-45-CC*	SHA-45-CC*		Drawer	
23.50"D SQ.HOLE	SER-45C-CC*	SEA-45C-CC*	SHA-45C-CC*		SKR-45-CC*	
29-3/16"D	SER-46-CC*	SEA-46-CC*	SHA-46-CC*			
• Compaq Spec.						
29-3/16"D	SER-46C-CC*	SEA-46C-CC*	SHA-46C-CC*			
• Power Strips	8 Outlet, 15A	16 Outlet, 15A	8 Outlet, 20A	8 Outlet, 20A	TwistLock	
	PSO848-15A	PS1648-15A	PSO848-20A	PSO848-20AT		
• Accessories	Casters (750lb.)	Coupler Kit	2 x 20W Halogen Light	MasterLock		
	CS-HD	CK-4	LB-0220	in Pairs Avail.		

